

SPRING HANGERS

(SHB- 100 Series 1" Deflection)

SHB series spring hangers are large diameter steel springs housed in rectangular steel brackets. The assembly incorporates dual (Steel and Elastomer) washers for uniform load distribution and high frequency isolation. These spring hangers are normally used in critical areas where noise and vibration need to be controlled.

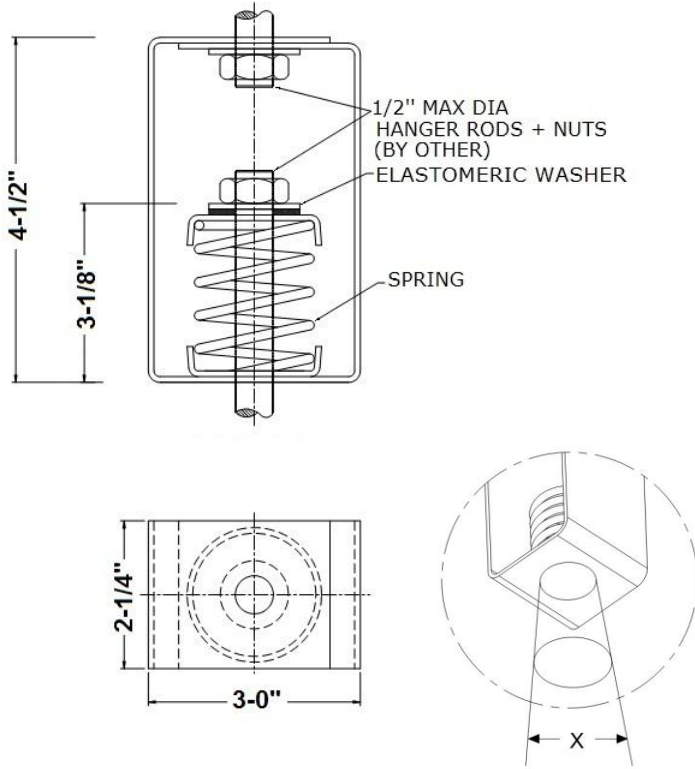

X = 46° For Spring 101 to 107



NOTES:

- Bracket: Blue Powder Coated
- Spring: Hot Dip Galvanized
- Design allows angular hanger misalignment
- Hanger Rods and Nuts not included

APPLICATIONS:

- Fan Coil Units
- Air Handling Units
- Fans
- Pipes
- Ducts

ISOLATOR MODEL	RATED LOAD (LBS)	RATED DEFLECTION (INCH)	COLOR	
			MAIN	STRIPE
SHB-101	60	1.3	SILVER	BLUE
SHB-102	100	1.3	SILVER	ORANGE
SHB-103	165	1.2	SILVER	BROWN
SHB-104	260	1.0	SILVER	BLACK
SHB-105	370	0.8	SILVER	YELLOW
SHB-106	450	0.5	SILVER	RED
SHB-107	700	0.45	SILVER	GREEN